

TECHNICIAN'S
**Non-Evaporable
Getter Pump
Component Manual**

Part No. 638391 Rev. C

Copyright © 2000
Physical Electronics, Inc.
6509 Flying Cloud Drive
Eden Prairie, MN 55344

The PHI logo is a registered trademark of Physical Electronics, Inc. Physical Electronics, PHI,
and  are trademarks of Physical Electronics, Inc.

All other trademarks are the property of their respective owners.

PHI Safety Notices

Physical Electronics' (PHI's) products are designed and manufactured in compliance with accepted worldwide practices and standards to provide protection against electrical and mechanical hazards for the operator and the area surrounding the product. All PHI products are designed and intended for professional use only, by skilled "operators" for their intended purpose and according to all of the instructions, safety notices, and warnings provide by PHI.

Those instructions, notices, and warnings assume that an "operator" will not employ any tool when using PHI products. They further assume that all operators clearly understand that use of PHI products in any manner not specified by PHI may impair the protection provided by the products and expose them to hazards.

A "technician" is a qualified servicing individual who:

- Has received training to work with voltages above 50 V,
- Has read and understood the PHI technician's manual for the equipment,
- Observes and understands all safety notices on PHI equipment.

The safety symbols that PHI uses are defined on the following page.* To reduce or eliminate hazards, technicians and operators of this equipment must fully understand these symbols.

PHI's products are installed with international-style or ANSI†-style safety notices, according to site requirements. International notices are symbols within triangles (alerts) or circles (mandatory actions). PHI's ANSI-style safety notices contain:

- One of three signal words (in all capitals) preceded by the general danger symbol ();
- One of PHI's safety symbols along with a brief description of the hazard and the risk or injury that could occur;
- Short message that observes ANSI's Hazard Alert Trilogy Rule by identifying the hazard, the possible result of ignoring the notice, and how to avoid the hazard.

The three signal words are defined as follows:

- **DANGER**—imminently hazardous situation that, if not avoided, will result in death or serious injury;
- **WARNING**—potentially hazardous situation that, if not

avoided, could result in death or serious injury;

- **CAUTION**—potentially hazardous situation or unsafe practice that, if not avoided, may result in minor or moderate injury or damage to equipment.

SEMI‡ standards require identification of type 3, 4, and 5 electrical maintenance tasks in equipment manuals:

- **Type 3** electrical maintenance tasks involve energized equipment, exposed live circuits, and possible accidental contact; potential exposures are less than 30 V RMS, 42.2 V peak, 240 V-A, and 20 J.
- **Type 4** is the same but potential exposures are greater than 30 V RMS, 42.2 V peak, 240 V-A, and 20 J or radio frequency is present.
- **Type 5** tasks involve energized equipment and measurements and adjustment require physical entry into the equipment, or equipment configuration will not allow the use of clamp-on probes.

Only experienced, trained technicians should attempt to perform type 3, 4, or 5 electrical maintenance tasks.

* Many of PHI's safety symbols are provided and copyrighted by Hazard Communication Systems, Inc., Milford, PA.

† American National Standards Institute, 1430 Broadway, New York, NY 10018.

‡ Semiconductor Equipment and Materials International, 805 E. Middlefield Rd., Mountain View, CA 94043-4080.

PHI Safety Notices



Voltages may be present that could cause death or personal injury.



A risk of death, personal injury, and/or damage to equipment exists (and a more specific label is not available).

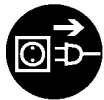

Pulling the plug from its power source before servicing is mandatory.



A pinching point is present that could cause personal injury.



A risk of explosion or implosion may be present that could cause personal injury.



Lifting with assistance or equipment could cause personal injury.



An overhead door is present that could cause personal injury. Do not work under door without auxiliary door supports installed.



Visible or invisible radiation may be present that could cause personal injury.



Hot surfaces may be present that could cause personal injury.



Turning off the power switch before servicing is mandatory.



Refer to the manual(s) before proceeding.



Contents are under pressure.



A harmful or irritant material may be present that could cause personal injury.



Extremely low temperatures may be present that could cause personal injury.



A risk of fire may be present that could cause personal injury.



A potentially dangerous magnetic field may be present.



An environment with depleted oxygen may be present that could cause death or personal injury. Open at least 2 doors and wait 2 minutes before entering the enclosure.



Wearing protective gloves is mandatory.



Wearing eye protection is mandatory.



Wearing foot protection is mandatory.



This is the location of the protective grounding conductor terminal.



This is the location of the fuse.



This is the location of an earth (ground) terminal.

Contents

PHI Safety Notices

Limited Warranty

1: Introduction	1-1
Description	1-1
Specifications	1-2
2: Installation	2-1
Handling NEG Modules	2-2
Inspection for Damage	2-2
Mounting NEG Modules	2-2
Flange Mounting	2-2
Internal Mounting	2-4
Connections	2-5
Connecting the Feedthrough	2-5
Connecting the Thermocouple	2-5
3: Operation	3-1
Recommendations for NEG Pump Use	3-2
Rough Pumping, Preliminary Outgassing, and Bakeout	3-3
Activation	3-4
Sorption	3-5
4: Service	4-1
Reactivation	4-2
Saturation	4-3
Replacement Parts	4-3
Troubleshooting Guide	4-4

Customer Service

Figures

1-1	Heating Curves of WP 1250 and WP 1250/2	1-2
1-2	Physical Dimensions — SAES Getters St 707 Wafer Modules	1-3
2-1	Flange-Mounted NEG.....	2-3
2-2	Internally Mounted NEG	2-4
2-3	Connecting High Current Feedthrough and Thermocouples.....	2-5
3-1	Activation Curves for NEG Modules	3-5

Tables

1-1	Specifications.....	1-2
3-1	Typical Current and Power Values for Various Pump Sizes.....	3-4
4-1	Replacement Part Numbers	4-3

Section 1: Introduction

The manual is divided into four sections. Section 1 contains a brief description and specifications of the Nonevaporable Getter (NEG) pumps. Sections 2 and 3 explain the installation and operation procedures, respectively. Section 4 provides service information.

Description

NEG pumps remove or pump active gases by *gettering* (chemically combining) gases with metal alloys. NEG modules are made of pleated copper-nickel alloy Constantan strips coated with St 707, a reactive zirconium-vanadium-iron powder mixture. St 707 reduces the chamber pressure by gettering or chemisorbing active gases like O₂, CO, and N₂ permanently on the surface of the getter base material. H₂ and its isotopes diffuse into the getter material forming a solid solution, which can later be released at higher temperatures. NEG pumps *do not* pump noble gases, but they can be used to purify the inert/noble gases.

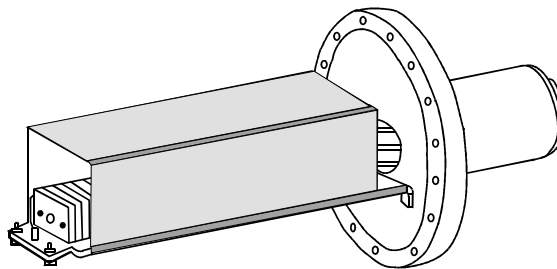

NEG modules offer high pumping speeds and help achieve an ultrahigh vacuum (UHV) environment quickly. They are most useful in applications requiring large specific pumping speeds, infrequent up-to air cycles, and a non-magnetic gettering process. NEG's are often used in conjunction with noble gas diode pumps, such as differential ion pumps. When combined, the two pumps provide high pumping speeds on a wider variety of gases, especially with high hydrogen gas loads or when H₂ is the primary remaining gas.

As the St 707 in the module becomes saturated with active gases, its pumping speed decreases. At the saturation point, heating it can reactivate the strip. This diffuses active gases like O₂, CO, and N₂ deeper into the wafer structure and releases the hydrogen, which can then be pumped out of the system by an ion or supporting pump.

The following table provides part numbers to order the various NEG modules.

	WP 750	WP 950	WP 1250	WP 1250/2
8" flange mount for double ended pumps	2150100	2150200	2150300	2150320
Internal mount (for tall pumps)	2151100	2151200	2151300	2151320

Specifications

Table 1-1. Specifications.

	WP 750	WP 950	WP 1250	WP 1250/2
H ₂ pumping speed *	330 l/s	430 l/s	560 l/s	770 l/s
CO pumping speed *	130 l/s	170 l/s	220 l/s	240 l/s
H ₂ sorption capacity *	660 l torr	840 l torr	1400 l torr	2800 l torr
Surface strip available	870 cm ²	1100 cm ²	1750 cm ²	3500 cm ²
Substrate thickness	0.2 mm	0.2 mm	0.2 mm	0.2 mm
Powder coating thickness	70 microns	70 microns	70 microns	70 microns
Total mass of getter material	33 g	42 g	70 g	140 g
Pump assembly weight	7.5 kg (16.5 lb)	7.7 kg (17 lb)	7.7 kg (17 lb)	8.1 kg (18 lb)
Shipping weight	17 kg (37.5 lb)	17.3 kg (38 lb)	17.3 kg (38 lb)	17.7 kg (39 lb)
Electrical characteristics	The ends of pleated getter strips are connected to electrical feedthroughs. AC/DC current can be passed through the strips to heat them as high as 600° C. Lower temperatures are recommended in order to maximize the number of reactivation cycles before failure. 450° C is optimum for activation and reactivation (Figure 1-1).			
NEG pump control characteristics	Resistive heating activates or reactivates the NEG module when high current passes directly through the pleated Constantan strip coated with St 707. Because a high current feedthrough is required in the vacuum chamber (which may be combined with an 8" flange), the NEG must be electrically isolated from the body of the chamber. NEG pump controls have an adjustable current source and timer.			

* At room temperature

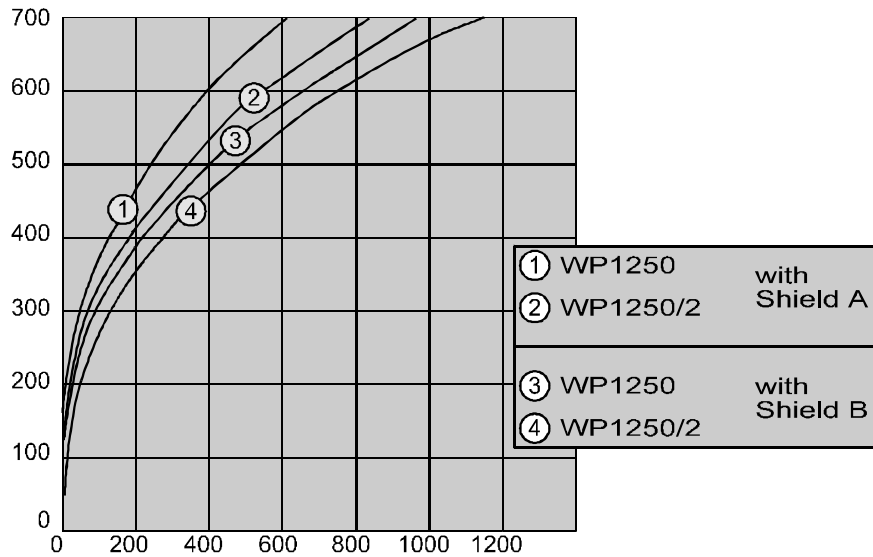

Figure 1-1. Heating Curves of WP 1250 and WP 1250/2.

Dimensions — mm (in.)

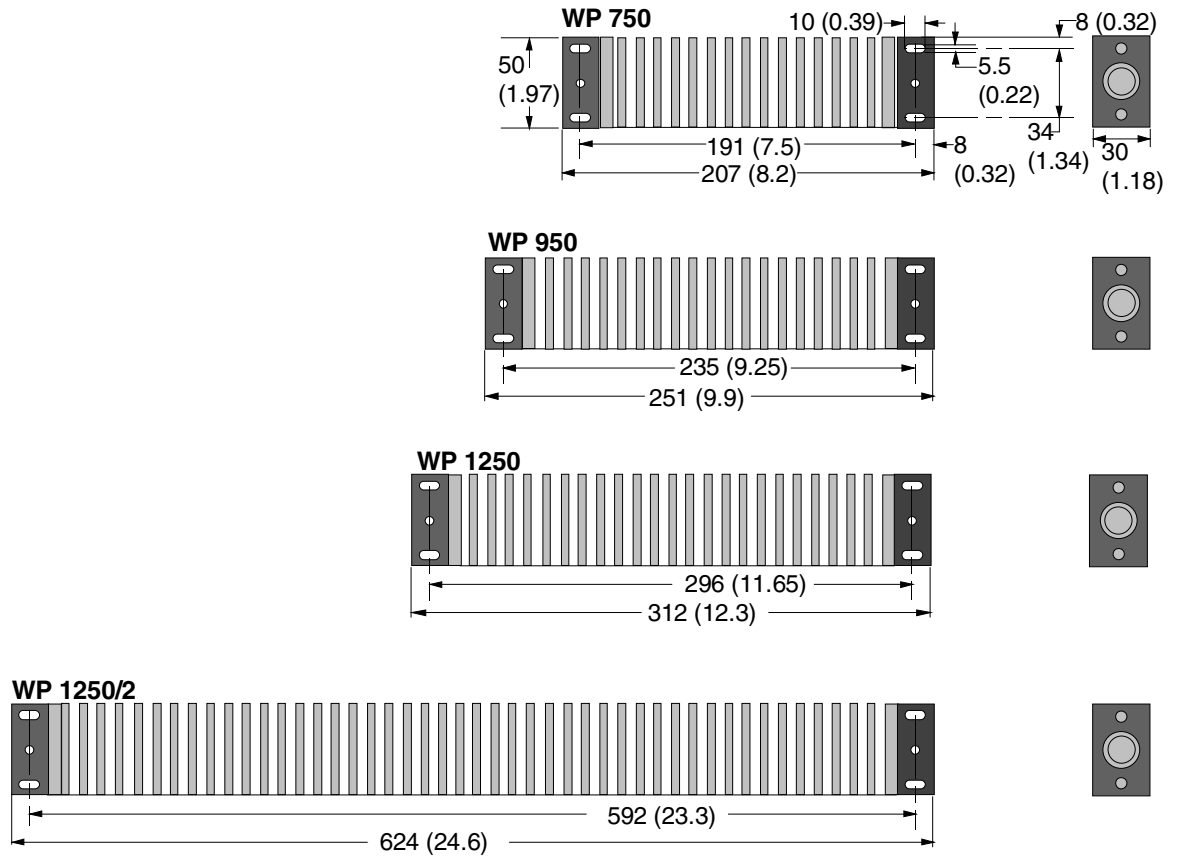

Figure 1-2. SAES Getters St 07 Wafer Modules.

Section 2: Installation

This section details the installation requirements for the Non-Evaporable Getter (NEG) modules.



WARNING: *Physical Electronics' (PHI's) products are designed and manufactured to provide protection against electrical and mechanical hazards for the operator and the area surrounding the product. The procedures provided in Sections 2 and 5 of this manual and in other PHI product manuals must be followed to ensure that these protections are not impaired in any way.*

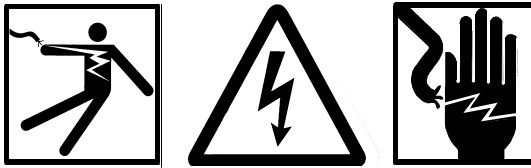

WARNING: *Installation procedures are for use by qualified and authorized personnel who have experience working with voltages greater than 50 volts. To avoid personal injury, do not perform any installation or service procedures unless qualified to do so.*

CAUTION: *Because the ceramic spacers that insulate NEG modules are breakable, handle the modules with care during assembly or removal of the pump. Accidental shocks could break the ceramic spacers and cause a short.*

Be sure the internal high current wiring does not touch the pump chassis. Because the wiring is not insulated, a short may result and damage the pump.

Handling NEG Modules



CAUTION: *The ceramic spacers that insulate NEG modules are breakable. Handle with care. Accidental dropping or similar shocks could break the ceramic spacers and cause a short circuit.*

Getter modules may be safely handled in the atmosphere before mounting them in your pumping system. However, to avoid contamination of the vacuum system:

- use cleanroom gloves or finger cots, and
- avoid using cotton or nylon gloves.

Inspection for Damage

NOTE: *It is the customer's responsibility to inspect and report any shipping damage to the carrier, typically within 30 days. Before installing PHI equipment, inspect it for obvious damage that may have occurred during shipment.*

Mounting NEG Modules

Depending on your application, the NEG module can be mounted in one of two ways:

- flange-mounted to an existing pump housing
- internally mounted

Flange-Mounting

If your NEG module requires flange mounting, perform the following procedure. [Figure 2-1](#) shows several views of the flange-mounted NEG.

1. Inspect the mating flanges for cleanliness and absence of scratches on the knife edge.
2. Place a new copper gasket between the pump flange and the vacuum chamber flange.
3. Use silver-plated bolts or apply a light coat of high temperature anti-seize lubricant to the screws.
4. Bolt mating flanges of the pump to the chamber.
5. Lightly snug all bolts, then sequentially tighten each one in turn. This will partially close the gap between the flange faces.
6. Repeat the sequential tightening for two or more cycles until the flange faces meet and a pronounced increase in torque is felt.

2: Installation

NEG Pump — Side View

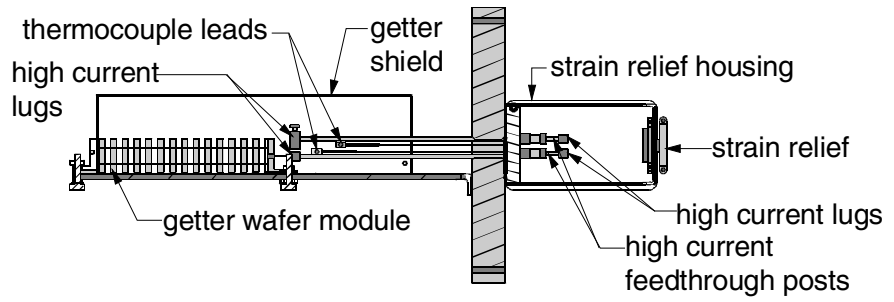

NEG Pump — Top View

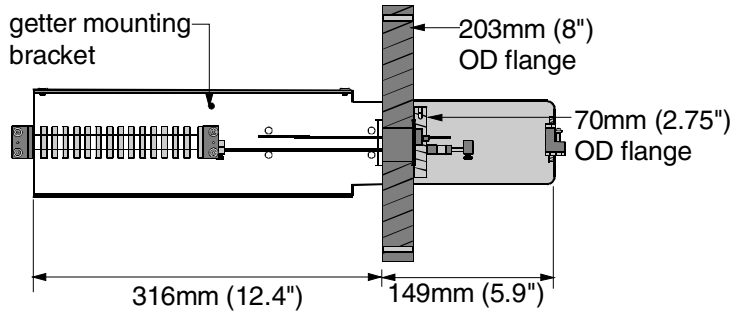

NEG Pump — End View

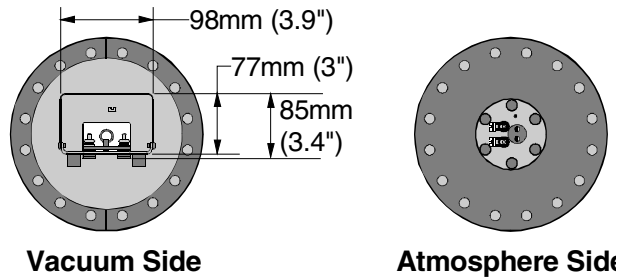

Figure 2-1. Flange-Mounted NEG.

2: Installation

Internal Mounting

To mount a NEG module internally, simply bolt it to the pump housing using the four bolts provided. Figure 2-2 shows several views of the internally mounted NEG.

Top View

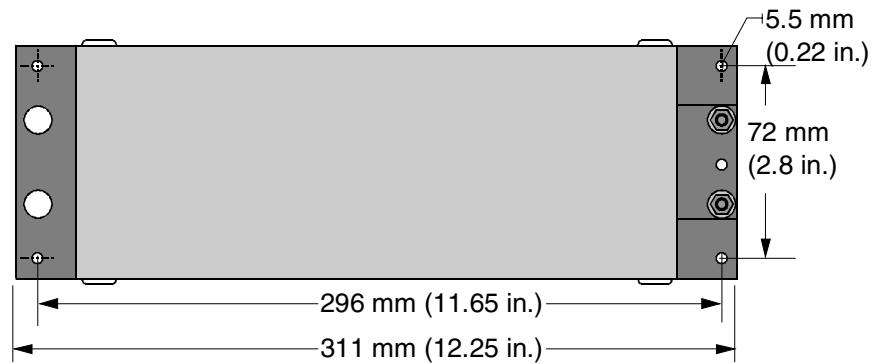

Side View

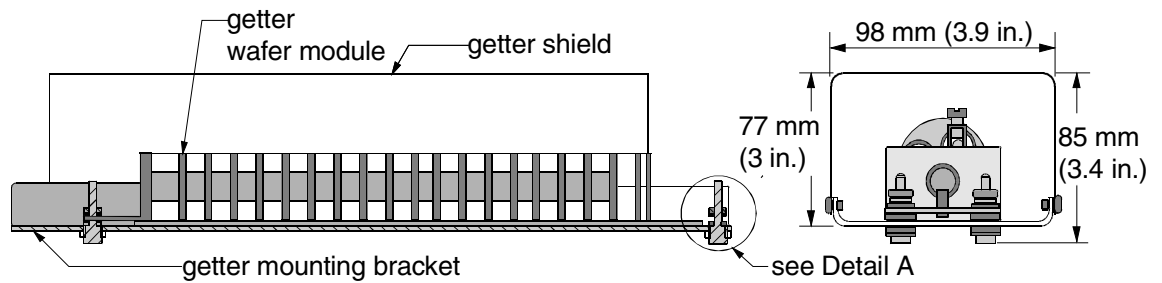

Detail A

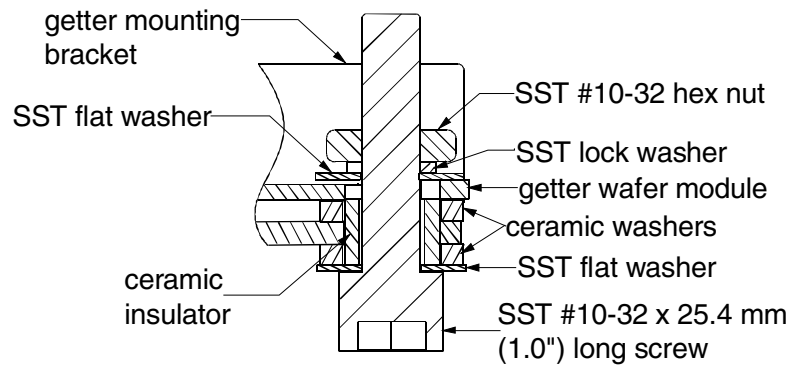

Figure. 2-2. Internally Mounted NEG.

Connections

See Figure 2-3 when connecting either the feedthrough or the thermocouple.

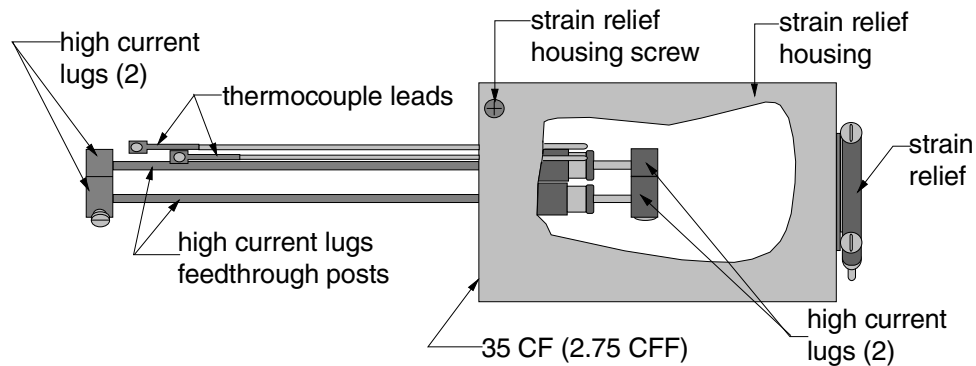

Figure 2-3. Connecting High Current Feedthrough and Thermocouples.

Connecting the Feedthrough

Connect the high current wiring to the terminals, located between the ceramic-mounting stand off, extending beyond the St 707-coated portion of the module. Each of these modules has two holes suitable for bolts and nuts.

1. Use solid copper uninsulated lead wire, which can handle the current necessary for activation.
2. Attach to the vacuum side of the feedthrough with copper lugs (PN 625695).
3. If you mount several modules adjacent to each other or in frames with rear shields, use at least one thermocouple in the central part of the shield.

Connecting the Thermocouple



CAUTION: *Be sure internal high current wiring does not touch the pump chassis. Because wiring is not insulated, a short may result and damage the pump.*

1. When a thermocouple is attached to the Constantan strip, the lead wires should be routed between the NEG module and the heat shield and then as directly as possible to the vacuum feedthrough.
2. The uninsulated thermocouple lead wires should not touch any component in the vacuum system between the thermocouple junction and the vacuum feedthrough, or incorrect readings will result, since the Constantan strip is resistively heated during reactivation.

Section 3: Operation

Operation of Non-Evaporable Getter (NEG) modules is controlled by the operator through the system computer software. Refer to the *System Operator's Guide* for specific operating procedures.

The following information and operating procedures are provided in this section:

- [Recommendations for NEG Pump Use](#)
- [Rough Pumping, Preliminary Outgassing, and Bakeout](#)
- [Activation](#)
- [Sorption](#)

Recommendations for NEG Pump Use

Recommendations for NEG Pump use provide the following operation guidelines.

1. Avoid air venting.

To extend the life of your getter module, vent the NEG module to dry N₂ when bringing your system up to atmosphere. When venting, *slowly* vent to dry N₂.

ATTENTION: Do not allow the UHV system to vent when the NEG module is at elevated temperatures and pressures, because the entire bulk of the NEG material could become saturated and require replacement.

In some cases, venting when the NEG pump is at high temperatures or sudden venting of a freshly reactivated NEG to air could cause the NEG material to spontaneously combust. The burning would be progressive, not explosive; nevertheless, the NEG pump would be damaged.

2. Avoid pumping these substances.

NEG pumps should be operated in accordance with the usual clean UHV procedures. Do not use your NEG modules to pump the following substances:

- hydrocarbons,
- arsenic and similar substances, or
- halogens such as chlorine and fluorine.

3. Maximum getter module temperature during activation and reactivation.

The ideal activation and reactivation temperature is 450° C. However, when the NEG module's pumping speed has slowed to 60%, reactivating it at temperatures as high as 700° C can restore most of its gettering capability.

NOTE: Maximum temperature during activation and reactivation should be 700° C. At higher temperatures, evaporation from the Constantan supports may begin to reach noticeable levels. At temperatures below 700° C, Cu evaporation is negligible.

3: Operation

4. Recommended upper limit of H₂.

The recommended upper limit of H₂ concentration does not correspond to the solid solution limit, but to the smaller value of 20 torr l/g of gettering alloy. Higher concentrations of H₂ may result in H₂ embrittlement, which causes loose particles to fall from the Constantan strips.

5. Ensure that the maximum pressure of 10⁻⁴ torr is not exceeded.

Use a sufficiently high pumping speed for roughing pumps, and set the getter temperatures at appropriate levels during the initial heating.

NOTE: Pressures of 10⁻⁴ torr or higher exhausts the getter strip's surface capacity quickly. If the getter strip is at elevated temperatures at pressures of 10⁻⁴ torr or higher, the entire bulk capacity of the strip can be exhausted quickly.

Rough Pumping, Preliminary Outgassing, and Bakeout

The following procedure needs to be performed initially after installation. This procedure must also be performed if your system is brought up to atmospheric pressure.

1. Use the roughing pump until the roughing pressure is as close as possible to your intended operating pressure. PHI recommends a minimum of 10⁻⁶ torr or below for UHV.
2. Plug the NEG pump control into a suitable outlet and turn power ON.
3. To speed the roughing cycle, heat the NEG pump for 5 to 10 minutes at 200° C at 10⁻⁴ torr or lower. This causes the module to outgas quickly into the roughing pump.
4. When a bakeout is part of the process, the activation or reactivation should take place at the end of the bake cycle. Using the NEG pump control, set the correct time interval and current to complete activation.
5. For non-baked systems, set the NEG pump control for the correct time interval and current to complete activation and keep the roughing valve open until the activating NEG can compensate for the pressure increase caused by the NEG heating (approximately 7 to 10 minutes).

Activation

NEG modules need to be activated when initially installed, and then reactivated periodically thereafter for optimum efficiency. Initial activation and subsequent reactivations are performed by applying current under vacuum (PHI recommends a minimum of 10^{-6} torr or below for UHV) until the proper temperature is reached. Table 3-1 shows typical values for various pump sizes.

The typical values in Table 3-1 refer to a single module with a shield and a thermocouple, mounted on the pleated Constantan strip. PHI provides a shield to prevent the getter modules from inadvertently heating other parts of the system.

If the shield and thermocouples have been removed, or if the getter modules are mounted farther away from the walls, the current values must be increased.

When several modules have to be electrically operated at the same time, both series and parallel connections must be considered, depending on the maximum allowable values of total current and voltage.

Table 3-1. Typical Current and Power Values for Various Pump Sizes.

Temp*	WP 750**		WP 950**		WP 1250**		WP 1250/2**	
	Current	Power	Current	Power	Current	Power	Current	Power
200° C	12	23	18	34	12	45	20	50
280° C	15	36	22	50	15	65	24	80
400° C	23	85	33	115	23	150	36	180
450° C	26.5	115	38	156.5	26.5	205	45	252.5
500° C	30	145	43	198	30	260	48	325
700° C	47	365	66	480	47	630	77	840

** Current is shown in amps and power is shown in watts.
 * 450° C is recommended.

ATTENTION: *If air suddenly enters the vacuum system during activation, when its temperature is 200° C or more, the Constantan strip could burn. The burning would be progressive, not explosive; nevertheless, the NEG would be damaged.*

If air does enter the system during activation, shut off the power immediately to minimize NEG damage.

The total pressure during activation should not exceed 10^{-4} torr.

3: Operation

Perform the following procedure to activate or reactivate your NEG modules.

1. Activation should be performed under a sufficiently good vacuum to avoid permanently exhausting the getter material by saturating it with active gases. The gettering efficiency is affected by the duration of the activation process as well as by the temperature at which it is activated.
2. PHI recommends activating for 45 to 60 minutes at 450° C for most UHV applications. In order to obtain the same final efficiency, a shorter activation time must be compensated with a higher temperature. See Figure 3-1.

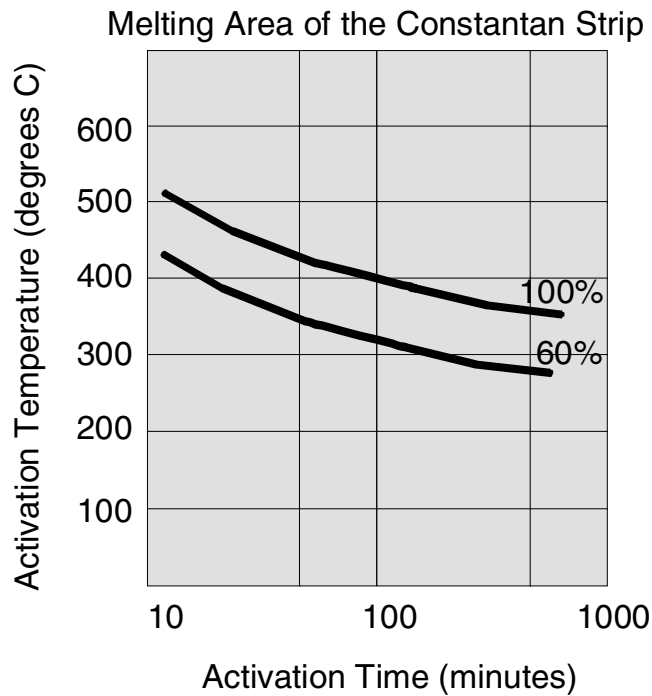

Figure 3-1. Activation Curves for NEG Modules.

Sorption

Hydrogen is sorbed by the NEG material, whereas all other getterable gases form stable chemical compounds. When a NEG pump is used in conjunction with an ion pump, PHI recommends operating the NEG pump at room temperature.

Section 4: Service

If the Nonevaporable Getter (NEG) pump fails to perform specified functions, seek the services of qualified personnel or contact PHI Customer Service:

By mail:

Physical Electronics, Inc.
PHI Customer Service, M/S G11
6509 Flying Cloud Drive
Eden Prairie, MN 55344
USA

By e-mail:

service@phi.com

By telephone or fax:

Region	Telephone	Fax
U.S.	1-800-922-4744	1-612-828-6325
Outside U.S.	1-612-828-5831	1-612-828-6325
Japan	81-46-785-6522	81-46-785-4411
Europe	49-89-96275-0	49-89-96275-50



WARNING: Performing any service tasks other than those described in this section without the assistance of PHI Customer Service could result in serious injury, could damage equipment, and may nullify applicable equipment warranties.

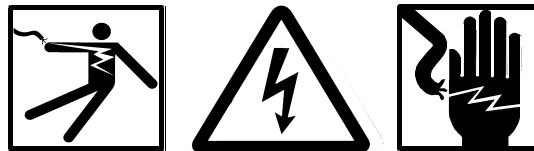

WARNING: Service procedures are for use by qualified and authorized personnel who have experience working with voltages greater than 50 volts. To avoid personal injury, do not perform any installation or service procedures unless qualified to do so.

Reactivation

There are three situations in which getter modules need to be reactivated:

1. As a getter module surface chemisorbes gases over time, the surface saturates and pumping slows to unacceptable speeds.
2. When the H₂-isotope levels are approaching embrittlement limit of 20 torr l/g.
3. NEG module needs reactivation after being exposed to atmospheric pressure.

In any of these cases, reactivation restores the gettering efficiency.

ATTENTION: *If air suddenly enters the vacuum system during activation, when its temperature is 200 °C or more, the Constantan strip could burn. The burning would be progressive, not explosive, but the NEG would be damaged.*

If air does enter the system during activation, shut off the power immediately to minimize NEG damage.

Temperature and duration of reactivation can vary depending on the application. For most UHV applications, reactivating for 45 to 60 minutes at 450° C is sufficient. To obtain the same final efficiency, a shorter duration must be compensated with a higher temperature of the treatment (see figure below). However, when the NEG module's pumping speed has slowed to 60%, reactivating it at temperatures as high as 700° C can restore most of its gettering capability.

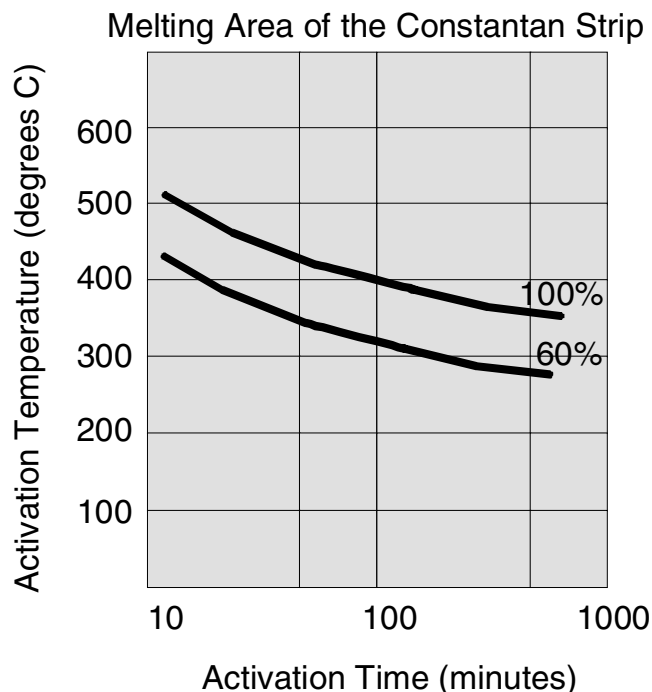

Saturation

The number of reactivations a getter module can undergo before it is exhausted depends on the application in which it is used and the number of times it is brought up to atmosphere.

- If it is brought up to atmosphere often and then reactivated, the getter module can be reactivated approximately 30 times.
- If it is not brought up to atmosphere, the getter pump lasts for approximately 60 reactivations.

Eventually the quantity of irreversibly sorbed impurities (such as O₂, CO, and N₂) increases to the point where the getter can no longer be reactivated and must be replaced. The modules are exhausted when the following quantities of active gases have been sorbed (q is in liter torr of the indicated gas):

$$q\text{CO} + q\text{CO}_2 + \frac{q\text{O}_2}{5} + \frac{q\text{H}_2\text{O}}{10} + \frac{q\text{N}_2}{4} = 2.2 \text{ torr l/g}$$

The sorption of this quantity would cause a decrease of the pumping speed of about 60% compared to that of a new getter module.

Replacement Parts

Table 4-1. Replacement Part Numbers.

Part Number	Description
623163	NEG wafer module WP750
623164	NEG wafer module WP950
623165	NEG wafer module WP1250
623166	NEG wafer module WP1250-2
625681	High current lug (air side)
625695	High current lug (vacuum side)
628452	Ceramic washer, 059 x 0.39, cleaned
628453	Ceramic insulator, 0.38 x 0.3
622909	Feedthrough-Thermocouple with plug
1004153	Resistor-10k Ω, 5W 5%

Troubleshooting Guide

Symptom	Corrective Action
NEG pump isn't heating.	<ol style="list-style-type: none"> 1. Check the NEG pump control for proper connection. 2. Check connections for overheating. Overheating indicates that connections aren't correct and should be repaired. 3. Verify that amperage is high enough for activation/reactivation.
Slow pumping speed or poor base pressure.	<ol style="list-style-type: none"> 1. Check for system leaks and repair if necessary. 2. Getter strips may be saturated and in need of reactivation.
Slow roughing.	Outgas first (see Section 3, the <i>Rough Pumping, Preliminary Outgassing, and Bakeout</i> procedure)
Roughing pressure doesn't level off.	Check for system leaks and repair if necessary.

Limited Warranty

Except as otherwise provided herein, the Seller warrants to Buyer that the equipment sold hereunder, whether it is new equipment or remanufactured (reconditioned) equipment, is, at the time of shipment to Buyer from Seller, free from defects in material and workmanship. As Buyer's sole exclusive remedy under this warranty Seller agrees either to repair or replace, at Seller's sole option and free of part charge to Buyer, any part or parts of such equipment which, under proper and normal conditions of use prove to be defective within 12 months from the date of receipt by the Buyer. Warranty period for equipment requiring installation by Seller will commence on completion of standard installation services. If customer delays installation beyond 45 days after delivery, the warranty period will commence to run 45 days after delivery. After installation, any realignment, readjustment, recleaning or recalibration, provided it does not relate to a proven defect in material or workmanship, shall be performed only at Seller's then current rates for service.

Exclusions and Limitations

It is recognized that some parts by their nature (expendable items) may not function for one full year; therefore, excluded from the foregoing warranty are filaments, anodes, cathodes, multipliers, retard grids, special ceramics, ionizers, along with other such parts mentioned in the applicable operating manual.

The foregoing warranty excludes certain major items or accessories specifically indicated on applicable price lists or quotations, as to which Seller passes to Buyer whatever warranty is provided to Seller by the manufacturer or the

specific warranty indicated by the price list or quotation.

This warranty does not cover loss, damage, or defects resulting from transportation to the Buyer's facility, improper or inadequate maintenance by Buyer, buyer-supplied software or interfacing, unauthorized modification or misuse, operation outside of the environmental specifications for the equipment or improper site preparation and maintenance.

Product Service

All claims must be brought to the attention of Seller within 30 days of the failure to perform.

Seller at his option may require the product to be returned to the factory, transportation prepaid, for repair.

Refund of Purchase Price

In lieu of the foregoing, Seller may at any time elect, in its sole discretion, to discharge its warranty by accepting the return of such equipment and refunding any portion of the purchase price paid by Buyer.

Software and Firmware Products

The sole exclusive warranty applicable to software and firmware products provided by Seller for use with a processor will be as follows: Seller warrants that such software and firmware will conform to Seller's program manuals current at the time of shipment to Buyer when properly installed on that processor. Seller does not warrant that the operation of the processor software or firmware will be uninterrupted or error free.

No other warranty is expressed or implied. Seller expressly disclaims the implied warranties of merchantability and fitness for a particular purpose.

Customer Service

Order Information

Call the order desk at 1-800-237-3603 or 612-828-6466 (FAX: 612-828-6322). When ordering any item, please give the order number and a description.

Assistance

If you have any questions regarding service, technical questions, or replacement parts, please contact:

Physical Electronics
Customer Service Dept.
6509 Flying Cloud Drive
Eden Prairie, MN 55344

Telephone: 1-612-828-6451 or toll free at 1-800-922-4744
Fax: 1-612-828-6325

Reconditioning

PHI will recondition your ion pump, usually within two weeks of approval. Call the service department to arrange shipment. Factory reconditioning includes:

1. Complete disassembly down to the basic component level.
2. Replacement of the following components:
 - high voltage feedthrough
 - ceramic standoffs
 - ceramic shields
 - pinch-off flange
 - gaskets and hardware
3. Novamax chemical cleaning of all reusable components.
4. Reassembly in a clean room environment.
5. Vacuum leak check.
6. Electrical checkout and start.
7. Bakeout.
8. Base pressure verification and return shipment under vacuum.

Reconditioning is guaranteed to original pumping specifications and carries a 6-month warranty.

Equipment

- The service department sells reconditioned high vacuum equipment. For a list of components and prices, contact the service department.
- Loaner electronic units are issued on a priority basis for customers who experience a unit failure within the warranty period.
- Rental electronic units are issued on a priority basis for customers who want to keep their systems on line during non-warranty repairs.